

**AWEA**  
**Electrical Guide to**  
**Utility Scale Wind Turbines**

## Contents

<b>I</b>	<b>Introduction.....</b>	<b>4</b>
<b>II.</b>	<b>Wind Turbine and Wind Plant Technology .....</b>	<b>5</b>
	Wind Turbine Power Regulation.....	5
	Wind Turbine Electrical Generator Configurations.....	8
	Direct connected asynchronous generator.....	8
	Wound-Rotor Induction Generator with Scalar Control of Rotor Current .....	10
	Doubly-Fed Induction Generator with Vector Control of Rotor Currents.....	11
	Electrical Generator with Full Power Conversion .....	13
	Wind Plant Infrastructure .....	15
	Distributed Wind Generation Applications.....	17
	Voltage and Reactive Power Control.....	18
	Options for Reactive Compensation and Voltage Control.....	18
<b>III.</b>	<b>Wind Turbine and Wind Plant Response to Grid Frequency and Voltage Variations .....</b>	<b>22</b>
	Steady-State and Small-Signal Behavior.....	22
	Dynamic Response .....	24
	Transient Response .....	27
	Short Circuit Contributions.....	27
	Direct-Connect Squirrel Cage Induction Generator .....	28
	Doubly-Fed Induction Generator with Vector Control of Rotor Currents.....	29

This document is an interim report on the state of windpower technology. The technology is changing steadily, and no document can be a complete summary. The standards for low-voltage ride-through, for example, are under discussion as this paper goes to press, so there is no attempt to review the performance of windfarms in this area. The descriptions of designs and performance are intended as background for decisions related to interconnection of windfarms.

The American Wind Energy Association warmly thanks the contributions of materials, time and funding that made this document possible. The following individuals made this possible: Jim Caldwell, Mark Goodwin, Mark Haller, Nick Miller, Rob Sims, and Mark Scher, and Bob Zavadil, who assembled and edited the final version. In addition, support was provided by the U.S. Department of Energy, and many members of the American Wind Energy Association.

## I Introduction

Wind energy and large wind turbines are becoming a generally accepted utility scale power generating technology. As of the end of 2003, about 6000 MW of wind powered generation was operating in the North America.

This document was created to provide guidance and technical information relative to the design, interconnection, and operation of utility scale wind energy projects.

The equipment and technology available for utility scale wind projects has certain unique characteristics that should be considered in order to construct and operate a reliable project consistent with good utility practice.

This information is intended to supplement interconnection standards and policies established by the local interconnection Utility, The North American Electric Reliability Council (NERC), and the Federal Energy Regulatory Commission (FERC).

This document provides information and special considerations for the design, interconnection, and operation of utility scale wind powered generation stations. Utility scale wind projects typically are comprised of a large number of wind turbines rated 0.6 megawatts to several megawatts for each unit. Projects include a medium voltage power collection system that ties all turbines together and delivers the project output to a central step-up substation for delivery to the utility system. The point of delivery with the utility system is often at transmission voltages of 69 kV or higher.

This information is intended to be used as a guide for the wind turbine manufacturer, project developer, and utility engineer in the design and interconnection of wind powered generating stations.

## II. Wind Turbine and Wind Plant Technology

Large wind plants differ from conventional electric generating stations in a number of aspects. While the objective of both types of installations – the production of electric energy for transport and delivery to end users – is the same, the constituent components of a wind plant, how it operates, and how it interacts with other elements of the power system are relatively unique. Conventional generating facilities are comprised of one to a few large units, each of which utilizes a synchronous generator and familiar auxiliary systems such as speed governors and excitation systems. For engineering studies of the power system, the characteristics and behavior of synchronous generators and their associated control equipment are well known.

A large wind plant connected to the transmission network consists of many tens to hundreds of individual generating units spread out over a significant geographic expanse. Each of these units is quite small relative to conventional generating units. The individual wind turbines are all connected to a common point of interface with the bulk grid via an extensive medium voltage collector system that might consist of overhead lines, underground cables, or some combination thereof. At various locations within this plant infrastructure that extends from the grid interconnection point to each individual wind turbine, additional equipment such as capacitor banks and switching devices are deployed.

The technology for converting mechanical to electrical energy in wind turbines also represents a significant departure from the much better-known synchronous generators. At present, induction generators are the rule in commercial wind turbines. The behavior of these machines, especially when combined with sophisticated control via power electronic controllers, can be markedly different than conventional generating units.

This chapter provides an overview of the technology, performance, and electrical characteristics of wind turbines and wind plants.

### Wind Turbine Power Regulation

A wind turbine converts kinetic energy in a moving air stream to electric energy. Mechanical torque created by aerodynamic lift from the turbine blades is applied to a rotating shaft. An electrical generator on the same rotating shaft produces an opposing electromagnetic torque. In steady operation, the magnitude of the mechanical torque is equal to that of the electromagnetic torque, so the rotational speed remains constant and real power (the product of rotational speed and torque) is delivered to the grid. Since the wind speed is not constant, a variety of control mechanisms are employed to manage the conversion process and protect the mechanical and electrical equipment from conditions that would result in failure or destruction.

In fairly steady conditions, the power extracted from the air stream by the turbine blades can be characterized by Equation 1:

$$P = \frac{1}{2} \cdot \rho \cdot \pi \cdot R^2 \cdot v^3 \cdot C_p \quad \text{Equation 1}$$

where

$\rho$  = air density (nominally 1.22 kg/m<sup>3</sup>)

R = radius of area swept by the turbine blades

v = speed of moving air stream

$C_p$  = “coefficient of performance” for the composite airfoil (rotating blades)

$C_p$  itself is not a constant for a given airfoil, but rather is dependent on a parameter  $\lambda$ , called the tip-speed ratio, which is the ratio of the speed of the tip of the blade to the speed of the moving air stream.

Since wind speed and air density cannot be controlled, and the radius of the blades is fixed, the performance coefficient is the only means for torque control. In some wind turbines, blades are designed so that  $C_p$  falls dramatically at high wind speeds. This method of aerodynamic torque control is known as *stall regulation*, and is limited to preventing turbine over-speed during extreme gust conditions and limiting maximum shaft power in winds at or above the rated value.

Large wind turbines employ a more sophisticated method of aerodynamic torque regulation that has benefits in addition to preventing mechanical over-speed. The performance coefficient can also be changed by adjusting the “angle of attack” of the blades, as is done on some modern propeller-driven aircraft. Figure 1 shows  $C_p$  as a function of  $\lambda$  for a modern wind turbine. Blade pitch adjustment allows the energy capture to be optimized over a wide range of wind speeds (even if the rotational speed of the shaft is relatively constant), while still providing for over-speed protection through large adjustments in pitch angle.

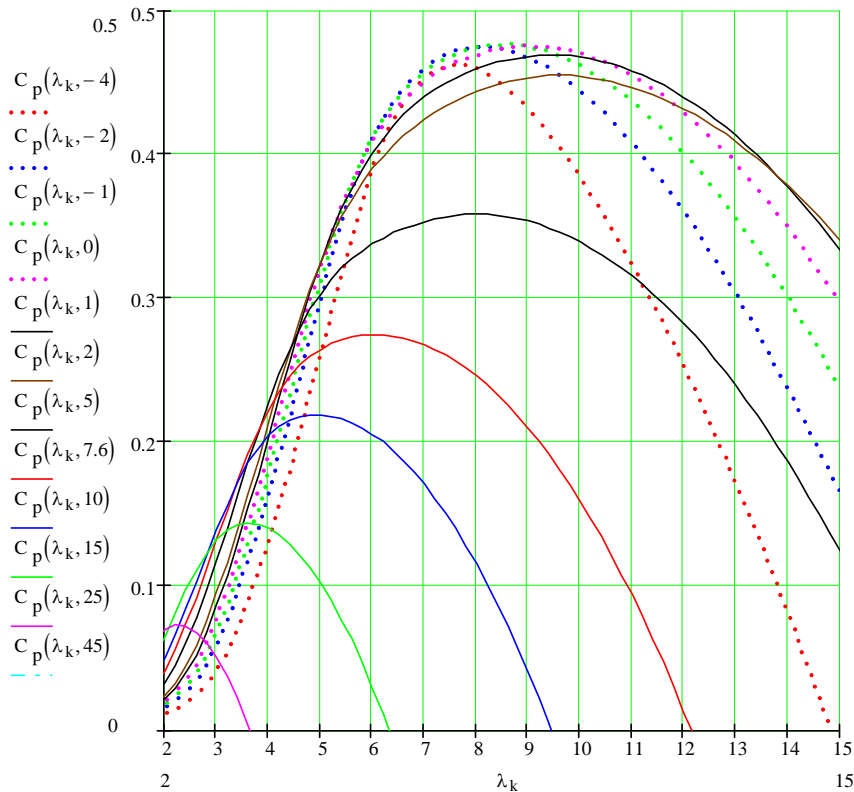

Figure 1: Coefficient of performance ( $C_p$ ) for a modern wind turbine blade assembly as a function of tip-speed ratio ( $\lambda$ ) and blade pitch ( $\beta$ , in degrees).

The pitch of the turbine blades is controlled by an actuator in the hub that rotates each blade about a longitudinal axis. The inertia of the blade about this axis and the forces opposing such a rotation of the blades are not negligible. Pitching of the blades, therefore, does not happen instantaneously, with the dynamics governed by the longitudinal inertia of the blades, forces acting on the blade (which can be wind speed and pitch dependent), and the torque capability of the pitch actuator mechanism.

The characteristic shown in Figure 1 is a “quasi-static” depiction of the blade performance, in that it does not account for turbulence effects, blade vibration or bending with respect to the average speed of rotation, or other asymmetries such as tower shadowing. It does, however, provide a much simpler means of incorporating the otherwise very complex details of the aerodynamic conversion process into models for electrical-side studies of the turbine.

The overall conversion of wind energy to electric power is normally described by a turbine “power curve”, which shows turbine electrical output as a function of steady wind speed (Figure 2). Such a representation is accurate only for steady-state operation, since the inherent dynamics of the mechanical and electrical systems along with all possible control functionality is neglected.

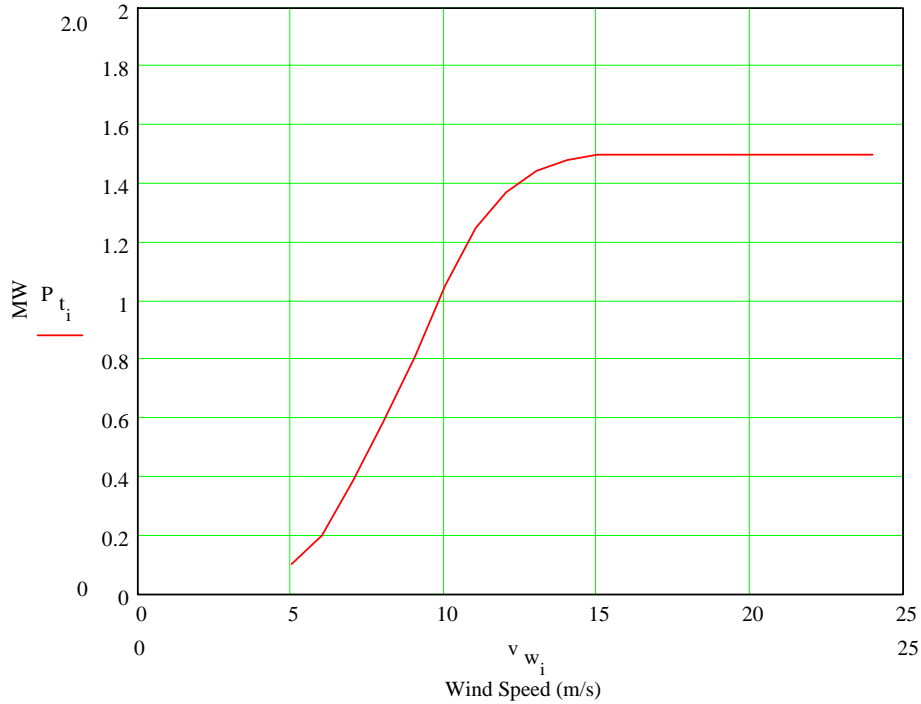

Figure 2: Power curve for a variable-speed, pitch-controlled wind turbine. Note “flatness” of output for wind speeds at or above rated value.

Rotational speeds of large wind turbines are partly limited by maximum blade tip speed, and so for megawatt-class turbines with long blades are relatively low, in the 15 to 30 rpm range. With conventional electrical generators, a gearbox is necessary to match the generator speed to the blade speed. The resulting mechanical system, then, has low-speed and high-speed sections, with a gearbox in between. For grid studies, the inertia of the gearbox can be lumped with that of the electrical generator, resulting in a mechanical equivalent circuit comprised of two masses – hub with blades and the electrical generator/gearbox combination – interconnected by a flexible shaft.

For megawatt-scale turbines, the mechanical inertia is relatively large, with typical inertia constants (H) of 3.0 seconds or larger (the inertia constant for the generator only will typically be about 0.5 s). The mechanical inertia is an important factor in the dynamic behavior of the turbine, because the large inertia implies relatively slow changes in mechanical speed for both normal variations in wind speed and disturbances on the grid. In addition, the various control systems in the turbine may utilize turbine speed as an input or disturbance signal, so that large inertia will then govern the response time.

With a two-mass mechanical model, there will be one oscillatory mode. With relatively flexible drive shafts in large wind turbines, the natural frequency of this primary mode of oscillation will be in the range of 1 to 2 Hz.

### **Wind Turbine Electrical Generator Configurations**

Almost all of the wind turbines deployed in large wind generation facilities in the U.S. over the past decade can be generally described by one of the following configurations:

- Stall-regulated (fixed-pitch) blades connected to a hub, which is coupled via a gearbox to a relatively conventional squirrel-cage induction machine. The generator is directly connected to the line, and may have automatically switched shunt capacitors for reactive power compensation and possibly a soft-start mechanism which is bypassed after the machine has been energized. The speed range of the turbine is fixed by the torque vs. speed characteristics of the induction generator.
- A wound-rotor induction generator with a mechanism for controlling the magnitude of the rotor current through adjustable external rotor circuit resistors, and pitch regulation of the turbine blades to assist in controlling speed. The operating speed range of the turbine is widened because of the external resistors.
- A wound-rotor induction generator with the rotor circuit coupled to the line terminals through a four-quadrant power converter. The converter provides for vector (magnitude and phase angle) control of the rotor circuit current, even under dynamic conditions, and substantially widens the operating speed range of the turbine. Turbine speed is primarily controlled by actively adjusting the pitch of the turbine blades.

While not represented in the present fleet of commercial turbines for application in the United States, the variable-speed wind turbine with a full-rated power converter between the electrical generator and the grid deserves mention here. The first utility-scale variable-speed turbine in the U.S. employed this topology, and many see this configuration reemerging for future large wind turbines. The power converter provides substantial decoupling of the electrical generator dynamics from the grid, such that the portion of the converter connected directly to the electrical system defines most of the characteristics and behavior important for power system studies.

#### ***Direct connected asynchronous generator***

Most wind generators installed at the end of the 20<sup>th</sup> century were ordinary asynchronous (induction) generators, usually with fixed capacitance to correct for the reactive power demands of that type of generator. An induction generator is essentially an induction motor where the slip is negative, i.e. the rotor speed is slightly ahead of the rotating flux in the stator winding. The induction generator has a squirrel cage rotor which draws magnetizing current from the stator giving rise to a high reactive power demand when fluxing, as when the generator circuit breaker is first closed.

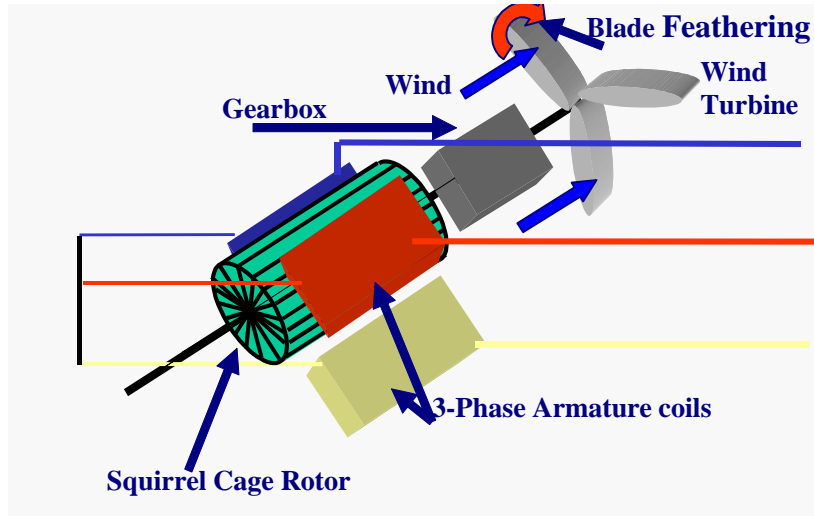

Figure 3: Wind turbine with a direct-connect asynchronous generator

The useful operating range of the generator lies between synchronous speed and a very small speed increase (negative slip).



Figure 4: Torque vs. speed characteristics for a squirrel cage induction generator.

The following classic figure shows how dramatically the reactive power demand from the network increases as the generator departs from a tight slip regime. For the machine shown, rated slip is about 0.8%, at which point the machine would draw 340 kVAR from a line with rated voltage. If the slip were increased to just 1.0%, the reactive power requirement increases to almost 480 kVAR. At 2.0% slip, reactive power consumption grows to 900 kVAR.

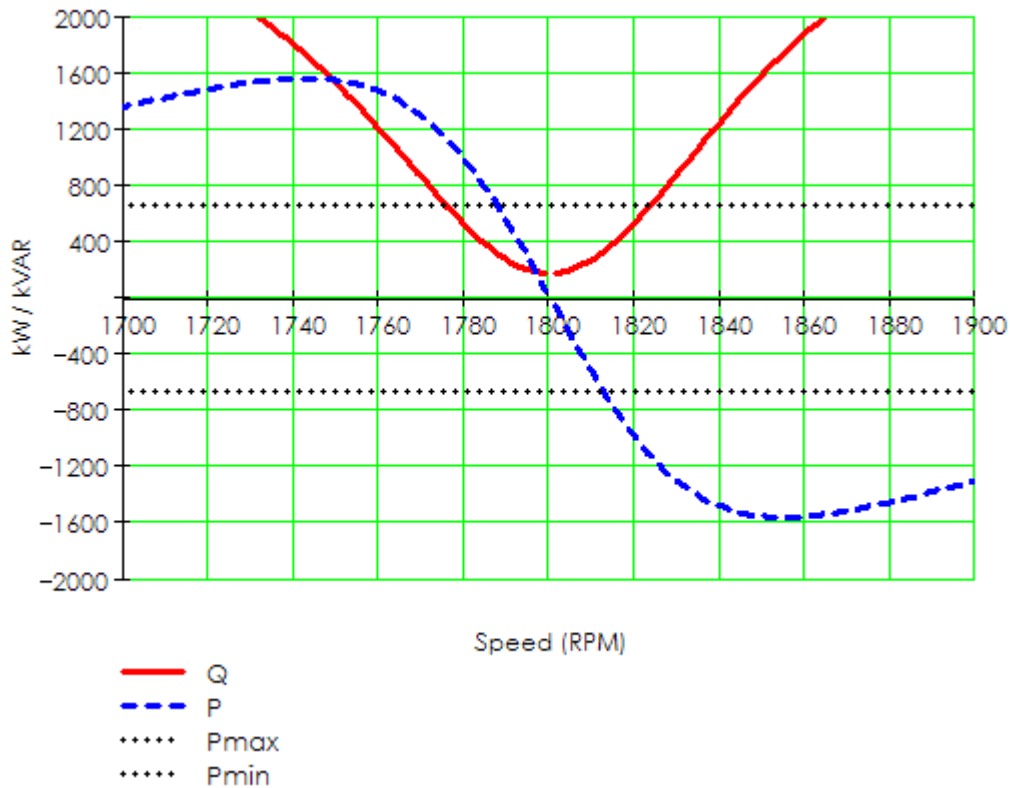

Figure 5: Variation of real (solid) and reactive (dash) power with slip for a squirrel-cage induction machine.

These diagrams are also useful in determining how much capacitance needs to be installed to return a machine to unity power factor. It is common practice to install mechanically switched capacitors as part of the wind farm and to size them so as to leave the entire assembly slightly inductive as seen from the grid. This inductive bias helps to prevent self-excitation of the generator in the event of separation of the wind turbine from the grid.

**Wound-Rotor Induction Generator with Scalar Control of Rotor Current**

In a squirrel-cage induction generator, the rotor “circuits” are fictitious and not accessible external to the machine, and the induced currents responsible for torque generation are strictly a function of the slip speed. The turbine shown in Figure 6 utilizes a wound-rotor induction machine, where each of the three discrete rotor winding assemblies is electrically accessible via slip rings on the machine shaft. This provides for modification of the rotor circuit quantities and manipulation of the rotor currents, and therefore the electromagnetic torque production. The Vestas turbines for domestic application (e.g. V47 and V80) utilize such a system for controlling the magnitude of the rotor currents in the induction generator over the operating speed range of the turbine. The system (Vestas Rotor Current Controller or VRCC) consists of an external resistor network and a power electronics module that modulates the voltage across the resistors to maintain a commanded rotor current magnitude. The operation of the VRCC is quite fast, such that it is capable of holding the turbine output power constant for even gusting winds above rated wind speed, and significantly influences the dynamic response of the turbine to disturbances on the grid.

The operation of the scalar rotor current control under steady conditions is illustrated in Figure 7. The continuously variable rotor resistance effectively allows the generator to operate on an infinite number of torque vs. speed curves. In the figure, curves are shown for 10% increments of the total

external rotor resistance. The maximum torque line shown on the graph corresponds to constant power at the nominal value. The curve is sloped as torque must decrease as speed increases to maintain constant power.

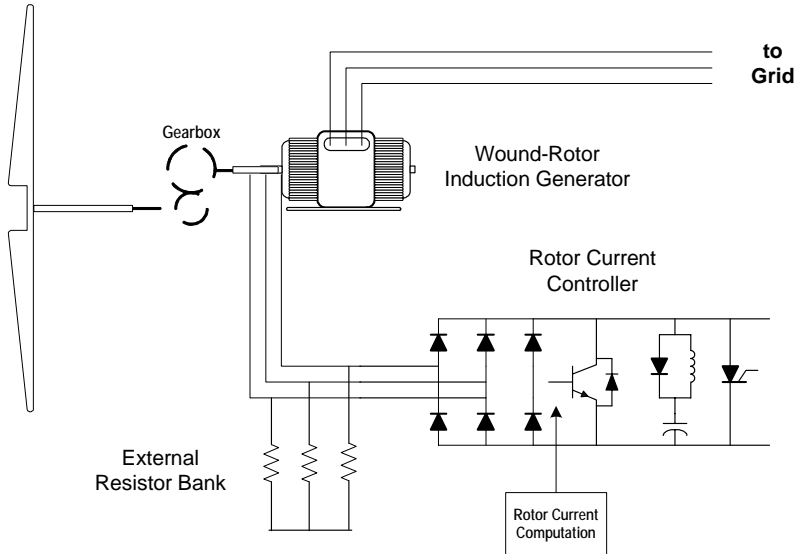

Figure 6: Wind turbine electrical generator with variable slip control.

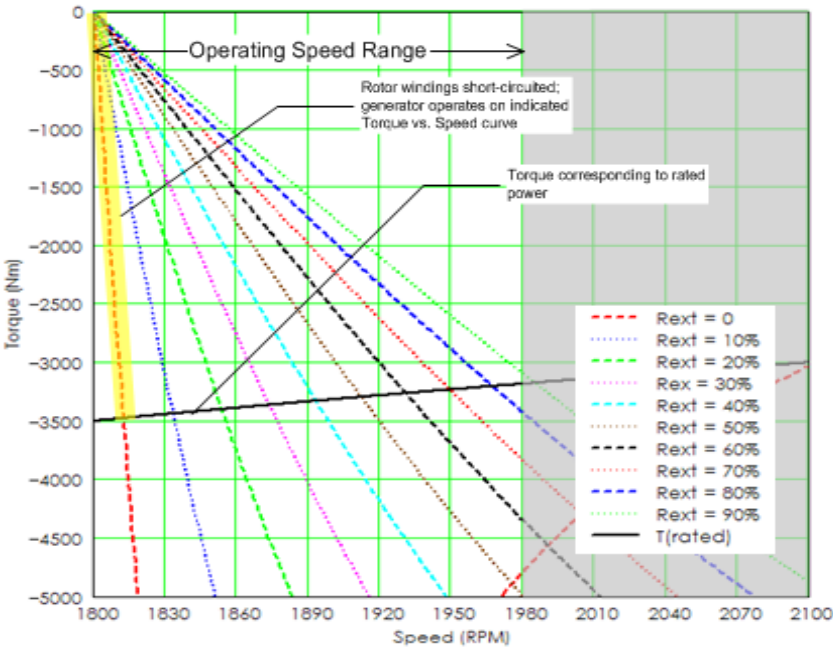

Figure 7: Operating characteristics for wind turbine generator with slip control.

**Doubly-Fed Induction Generator with Vector Control of Rotor Currents**

An even more sophisticated rotor current control scheme can be employed in a doubly-fed induction generator as shown in Figure 8. Here the rotor circuit is supplied with current from a four-quadrant voltage-source, current-regulated power converter. With respect to the grid frequency, such a converter can provide nearly instantaneous regulation of its output currents.

Under steady operating conditions, the machine-side converter controls the magnitude and phase of currents in the rotor circuit to achieve desired values of electromagnetic torque. Reactive power flow into the line-connected stator terminals of the generator can also be controlled.

Field-oriented or vector control of induction machines is a well-known technique used in high-performance industrial drive systems, and its application to wind turbines brings similar advantages. Commanded torque (and therefore the magnitude of the rotor current component responsible for torque production) can be linked to the speed of the machine via a “look-up” table. The field-orientation algorithm effectively creates an algebraic relationship between rotor current and torque, and removes the dynamics normally associated with an induction machine. The response of the power converter and control is fast enough to maintain proper alignment of the torque-producing component of the rotor current with the rotor flux so that the machine remains under relative control even during significant grid disturbances.

The line-side converter either absorbs or provides real power to the grid, depending on the operating speed of the generator. If the generator is operating below the synchronous speed for the grid frequency and pole number, some amount of real power will flow through the line-side converter to the dc link, then from the machine-side power converter into the rotor circuit. If the turbine is operating above synchronous speed, real power will flow in the opposite direction.

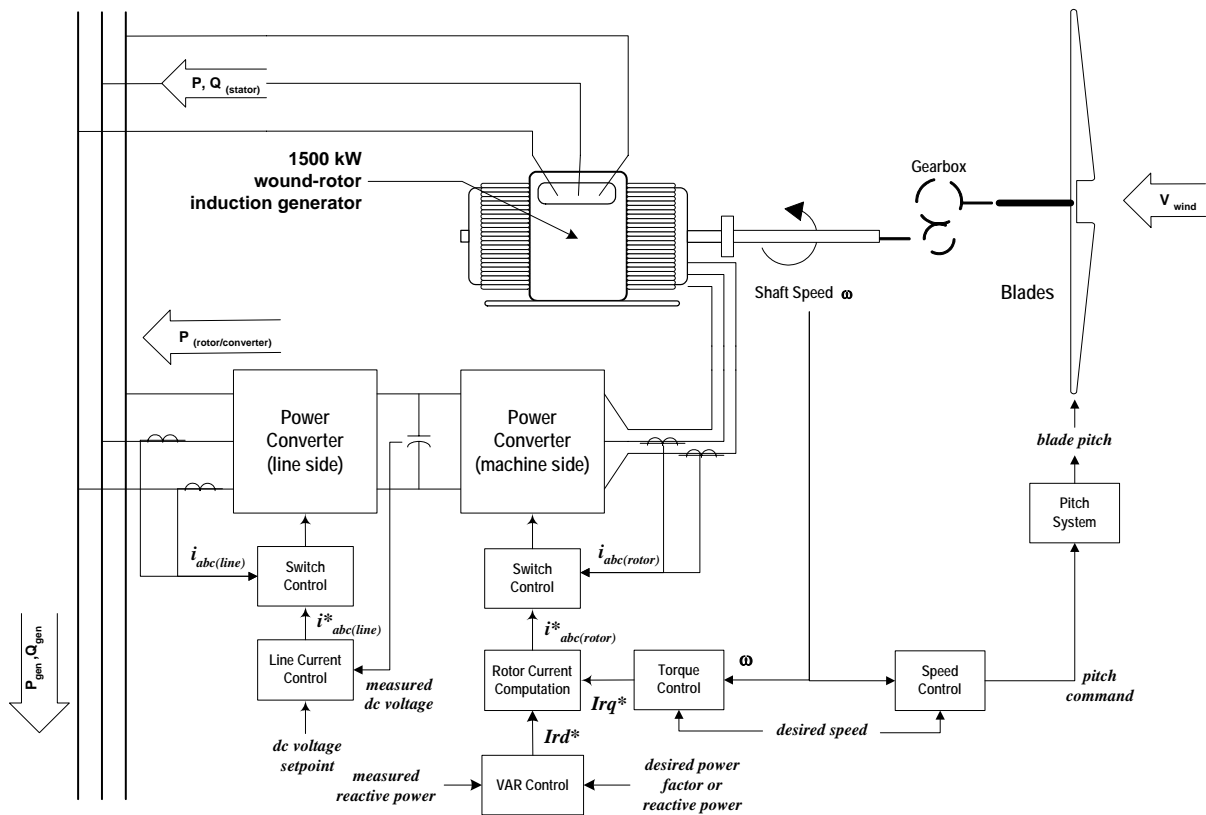

Figure 8: Configuration of a wind turbine with four-quadrant power converter supplying rotor circuit of a wound-rotor induction generator. Control blocks for torque control also shown.

The stator is connected to the low voltage side of the wind turbine transformer, but in the case of the DFIG the rotor is a 3-phase coil winding connected to a variable frequency power electronic drive via slip rings rather than an internally short circuited winding. Active power is drawn from the grid to supply the rotor via an AC/DC and DC/AC voltage source converter link and the rotor currents can be completely controlled by the IGBT control circuit. The frequency, which the rotor side converter targets, is that which when superimposed on the rotor speed gives rise to a synchronously rotating field in the air gap.

The active power exchange with the grid is the sum of the power supplied to the grid from the generator stator and the power exchanged with the rotor (minus the converter losses). The stator always exports active power to the grid.

The DFIG machine has a number of advantages over the induction generator. Because the rotor frequency is essentially decoupled from the grid, it can operate over a wider slip range (e.g. +/- 20%) compared to 0 to 2% for a conventional induction machine. The connected DFIG wind turbine is not restricted to a single unique operating speed. This allows the blade tip speed to be varied over a range to better match the wind speed and maintain an efficient operating position for a range of wind speeds.

Reactive power is controllable. The initial machine magnetization flux is established from the rotor and the grid side converter still draws only active power. The reactive power is created by the rotor side converter by the firing angle and thus the field angle relative to the rotating field in the stator. The stator similarly appears as a unity power factor device even at starting. Where the turbine control system is required to supply or absorb reactive power, the lead or lag of the rotor field can be controlled by the rotor side converter. Since the synchronous rotor field vectors can be shifted angularly as in the lead and lag of a synchronous machine, the machine can be modeled with direct (d) and quadrature (q) axis components.

The phase difference and magnitude of the rotor voltage determine the active and reactive power which is delivered to the terminals of a DFIG. In an ideal device, maximum active power exchange takes place at  $\alpha = 90^\circ$  or  $270^\circ$  at which time there is no reactive power exchange. Reactive power exchange is maximized at  $\alpha = 0^\circ$  and  $180^\circ$ .

The DFIG can therefore manage active and reactive power independently by controls on the grid and rotor side converters. It requires a converter-inverter arrangement, but the maximum expected power through the converter to or from the rotor is about 25% of the total output power of the generator. Therefore the converters are cost effective. There is however a downside to the technology. Under serious system fault conditions the grid voltage may be close to collapse and attempts to meet a target voltage or power factor will drive very high currents into the rotor and hence through the power converters. The converters would be thermally damaged by these currents, so the equipment is generally closely protected by an electronic rotor short circuiting mechanism, often called the "crowbar". This can be active within 20ms and is followed immediately by a machine trip. Conventional synchronous generators supply reactive energy to the fault and then on fault clearance they participate in the system recovery.

#### ***Electrical Generator with Full Power Conversion***

The Kenetech 33 MVS, introduced commercially in the early 1990's, was the first utility-scale (i.e. large) variable-speed wind turbine in the U.S. The turbine employed a squirrel-cage induction generator with the stator winding supplied by a four-quadrant power converter (Figure 9).

In this configuration, a wide range of electrical generator topologies could be employed – asynchronous, conventional synchronous, permanent magnet, etc. Because all of the power from the turbine is processed by the static power converter, the specific characteristics and dynamics of the electrical generator are effectively isolated from the power grid.

A modern static power converter utilizes power semiconductor devices (i.e. switches) that are capable of both controlled turn-on as well as turn-off. Further, the device characteristics enable switch transitions to occur very rapidly relative to a single cycle of 60 Hz voltage – nominal switching frequencies of a couple to several kHz are typical. This rapid switching speed, in combination with very powerful and inexpensive digital control, provides several advantages for distributed generation interface applications:

- Low waveform distortion with little passive filtering
- High-performance regulating capability
- High conversion efficiency
- Fast response to abnormal conditions, including disturbances, such as short-circuits on the power system
- Capability for reactive power control

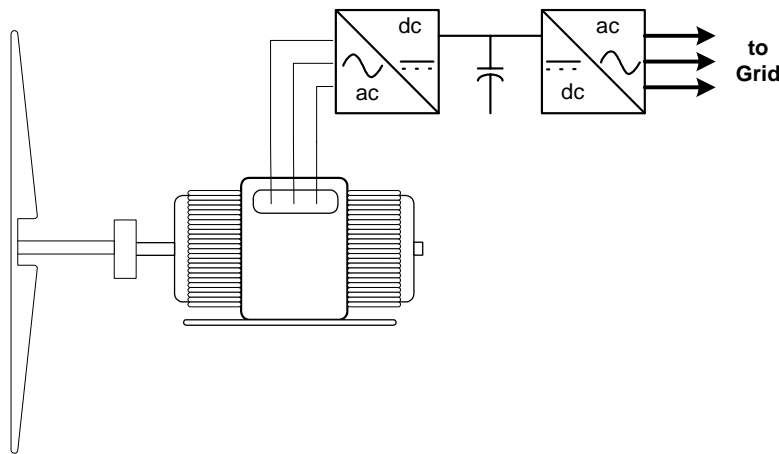

Figure 9: Wind turbine electrical generator with full power conversion.

Because the effective switching speed of the power semiconductor switches is quite fast relative to the 60 Hz power system frequency, it is possible to synthesize voltage and current waveforms with very little lower-order harmonic distortion. Most modern converters easily meet limits on these harmonics found in the IEEE 519 standard.

Figure 10 depicts a simplified control schematic for a static power converter in grid-parallel operation. Since an individual wind turbine is likely small in rating relative to the short-circuit capability of the system to which it is connected, the voltage magnitude at this point will only be slightly influenced by the operation of the turbine. The control scheme, therefore, is designed to directly regulate the currents to be injected into this “stiff” voltage source.

The ac line voltages, dc link voltage, and two of the three ac line currents – for a three-wire connection - are measured and provided to the main controller. The ac voltage and line currents are measured at a high resolution relative to 60 Hz, so that the controller is working with instantaneous values. By comparing the measured dc voltage to the desired value, the controller determines if the real power delivered to the ac system should be increased, decreased, or held at the present value. Such a simple regulation scheme works because there is no electric energy storage in the converter (except for that in the dc filter capacitor), so the energy flowing into the dc side of the converter must be matched at all times to that injected into the ac line. If these

quantities do not match, the dc link voltage will either rise or fall, depending on the algebraic sign of the mismatch.

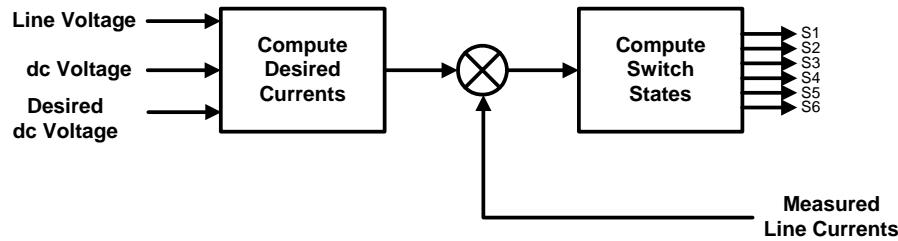

Figure 10: Simple output current control stage for a static power converter in a grid-tied DG application.

The error in the dc voltage is fed into a PI (proportional-integral) regulator to generate a value representing the desired rms magnitude of the ac line currents. Another section of the control is processing the instantaneous value of the ac line voltage to serve as a reference or “template” for the currents to be produced by the converter. The desired instantaneous value of the line current is computed by multiplying the desired rms current magnitude by the present value from the template waveform. In the next stage of the control, often times called the “modulator” section, the desired instantaneous value of line current is compared to the measure value (in each phase). The modulator then determines the desired state of the six switches in the matrix based on the instantaneous current error in each phase of the line currents. The states are transmitted to the IGBT gate drivers, which then implement the state of each IGBT in the matrix as commanded by the controller. The process is then repeated at the next digital sampling interval of the overall control.

The process is repeated thousands of times per single cycle of 60 Hz voltage. By using the line voltage as a template for the shape of the currents to be synthesized, synchronism is assured. Additionally, if there is no intentional phase shift introduced in the control calculations, the currents will be almost precisely – save for small delays introduced by the control itself - in phase with the line voltages, for unity power factor operation. The small errors that are continually corrected by the action of the converter control introduce some distortion into the ac current wave shape. Because of the high switching speed, however, the distortion is low, well within IEEE 519 limits.

## Wind Plant Infrastructure

Wind turbines are just one (albeit the critical) component of bulk wind plants. With individual turbine sizes now exceeding 1 MW, nameplate ratings for single wind plants of many tens to hundreds of MW are common. The geographic extent of the wind plant must be large enough to not only accommodate the dozens to a hundred or more turbines, but also allow optimal spacing and utilization of local terrain features that will maximize energy production. The infrastructure for connecting a large number of widely distributed turbines to a single point of interconnection with the transmission system has important influence over the electrical characteristics of the wind plant.

The installed and proposed utility-scale wind plants in the U.S. have some common design characteristics that offer potential simplifications for constructing aggregated models for transmission system studies. These commonalities stem from practicalities and optimizations regarding the local wind regime, micro-siting of individual turbines, electric system design, and operations and maintenance economies. The result is that, from the power system modeling perspective, large wind plants have the following features in common:

- **A single turbine type** – Since wind turbines are complex machines that require preventative, predictive, and on-demand maintenance to achieve the highest availability, it is better from a maintenance and operations perspective to utilize the same turbine throughout the wind plant and have a maintenance and operations staff that specializes in all aspects of this single turbine design.

Individual wind turbine generators (WTG's) typically generate at voltages ranging from just under 600 V. Each turbine will normally be equipped with a generation voltage to medium voltage (typically 12.47 – 34.5 kV) step-up transformer that is either an integral part of the WTG assembly or installed adjacent to the WTG.

- **Medium voltage collector systems and interconnect equipment** – The electrical infrastructure which “collects” power generated by each turbine in the plant and delivers it to the transmission system utilizes standard overhead and underground medium voltage (15 to 35 kV) equipment and design practices. Some variations from standard utility practice for medium voltage design are necessary, however, as the operation of wind turbines varies significantly from the distributed end-use loads for which the utility distribution engineering practice is optimized. For example, voltage regulation and protection schemes must be modified to account for generation, rather than load, distributed along the collector lines. The collector lines are an integral part of the wind plant; i.e. they are not utilized to serve non-wind plant load or other electric utility customers.

In a large utility scale wind generating facility, the collection circuits emanate from a transmission interconnection substation consisting of the following major components: medium voltage circuit breakers and associated protection / control / monitoring equipment; a station power transformer on the medium voltage bus; an alternate source of station service power (typically either an alternate low voltage service from the local utility or a back-up diesel or natural gas generator); one or more step-up transformers to utility interconnection voltage (typically 69 kV or higher); transmission voltage circuit breakers and associated protection / control / monitoring equipment; voltage control and reactive power compensation equipment; and revenue metering.

Smaller scale wind generating facilities can be interconnected to utility medium voltage distribution or sub-transmission systems. In this case, there may be an interconnection substation with collection and interconnection circuit breakers or other type of switchgear, associated protection / control / monitoring equipment, voltage control and reactive power compensation equipment, and revenue metering.

- **Reactive compensation** – Maintaining voltages within tolerances at individual turbines within a wind plant while at the same time meeting power factor or voltage regulation requirements at the point of interconnection with the transmission system requires careful management of reactive power. Typical locations for reactive power compensation within a wind plant are 1) at each individual turbine, dependent on the reactive power requirements and characteristics of the rotating machinery in the turbine; 2) at the interconnect substation in the form of switched shunt capacitor banks; and 3) at locations along the medium voltage collector lines depending on the layout of the plant. Some plants have the ability to dynamically control reactive power from each turbine, which offers the possibility of reactive power management for transmission system considerations to be accomplished by the turbines themselves. Terminal voltages at individual turbines, however, may be a constraint on the amount of reactive power that can be delivered to the interconnect substation during periods of high wind generation. In addition, when reactive power is required at the point of interconnection to the transmission network to support voltage, substantial reactive

power may be “lost” in the medium voltage collector system between individual wind turbines and the interconnect substation.

- **SCADA and Plant Control** – Large wind plants typically have fairly extensive means for remote operation of individual turbines and collection of high-resolution operating data. As wind plants become larger, both in individual size and as a share of the total generation in a control area, real-time or high-speed communications interfaces to control area operations centers and other outside organizations (e.g. wind generation forecasting services) will be desirable and possibly be required.

The operational requirements for wind plants are also likely to become more sophisticated over the coming years. At present, plant control is responsible primarily for the startup and shutdown of individual or groups of wind turbines, and restoration following grid outages. Future capabilities that may be required or desirable include power ramp rate control and forced partial curtailment, provision of short-term (e.g. hour) production forecasts, preparation of next-day generation schedules or bids, and implementation of voltage control schedules.

### **Distributed Wind Generation Applications**

The previous discussion focuses on wind turbines and large wind plants that connect directly to a transmission network. While the plant electrical infrastructure has many similarities to a utility distribution system, it is not used to deliver electric energy to individual customers.

Declining costs of wind energy are attracting the interest of independent operators, municipalities, and small cooperatives, and have given rise to a growing number of small wind energy installations. In these projects, a small number (one to a few) of wind turbines are connected to a utility distribution system, as the cost of a higher voltage interconnection could not be justified. Some of these projects utilize the same commercial wind turbines employed in bulk wind generation facilities with ratings between 1 and 2 MW.

While the technical issues are similar to those encountered in the design of a large wind plant connected to the transmission network, the distributed wind application brings with it some special considerations because 1) the distribution network to which the turbines are connected is not owned by the turbine operators, and 2) other customers are served by the distribution feeder to which the turbines are connected.

Technical questions for distributed wind generation applications are actually part of the larger category of interconnection issues for distributed generation. Many of the design and operating issues for wind turbines on public distribution feeders are related more closely to the connection of a second source of electric potential to a radial system designed for a single source rather than any of the unique characteristics of wind turbines or wind generation. Some issues, such as voltage flicker, may be of greater interest with wind generation.

A recent power industry effort has resulted in the adoption of IEEE Standard 1547 which addresses minimum requirements for the connection of distributed generators to utility distribution systems. While a solid first step, there are a number of unresolved technical, institutional, and regulatory questions concerning distributed generation in general. On the technical level, the novelty and unfamiliarity of the distributed technologies, the lack of substantial field experiences with these technologies, and the costs and complexity associated with thorough engineering evaluations of new distributed generation installations are major barriers.

By default, wind turbines for distributed applications must adhere to the basic requirements laid out in IEEE Std. 1547. Learning from existing distributed installations will also be important for

helping the wind and power industries move up the learning curve with regard to the unique characteristics and requirements of such applications. Finally, the lessons learned must be embedded in engineering tools for screening and evaluation appropriate for a much wider audience.

Research in this area is in progress.

### **Voltage and Reactive Power Control**

Electric power systems must be designed so that voltages at all nodes in the network are maintained within specified tolerances for all anticipated operating conditions. Managing reactive power is a key to regulating voltage in the network. To effectively manage the voltage profile in the network, reactive power must be provided in the right amount, at the right locations, and at the right times.

Most electric power systems have a natural deficit of reactive power because the individual system elements consume more reactive power than they provide. Various sources of reactive power are managed to overcome this deficit. Conventional electric generators are a primary source of reactive power, and can also be controlled to consume reactive power. As a result, generating unit excitation control is an effective means for regulating voltage in their electrical vicinity.

At locations electrically distant from conventional generating sources, voltages will vary with loading and power flow through the network. Other sources of distributed reactive power are employed for voltage support and regulation at these locations. Shunt capacitor banks – fixed or switched - are a primary source of reactive power. More sophisticated devices, such as static var compensators, have the added advantages of continuous control and fast, transient-free adjustment.

In a wind plant, there are three candidate locations where reactive power might be provided:

- At individual wind turbines
- Along the medium voltage collector lines
- At the connection point to the transmission network (interconnection substation)

The optimum location or locations for reactive power compensation in a wind plant depends on a number of factors. Voltages along the collector lines and terminal voltages at each individual wind turbine must be maintained within tolerances under all possible combinations of wind conditions across the expanse of the plant. At the same time, the reactive power needs of the transmission network at the interconnection point must be met. Additionally, the dynamic nature of wind generation must be considered, as the fluctuating output of individual wind turbines will require that some of the reactive compensation be adjustable as conditions change. Switched shunt capacitor banks, for instance, may not be capable of providing the dynamic response or fine control necessary for good voltage regulation.

These design objectives can sometimes be in apparent conflict. For example, in systems utilizing dynamic reactive power control capability of individual wind turbines, generating reactive power to support the transmission network will cause voltages at the turbine terminals to rise. Reactive losses in the collector lines (especially with overhead construction) may also be a major factor when reactive power is produced remote from the interconnect substation.

#### ***Options for Reactive Compensation and Voltage Control***

Reactive compensation for a wind plant must be designed to meet specifications at the point of interconnection to the transmission network and to manage terminal voltage at each individual wind turbine under all normal operating conditions.

Individual wind turbines will either have 1) a combination of fixed and switched shunt capacitors at their terminals to maintain power factor within prescribed limits over the range of its operation, or 2) the ability to dynamically control power factor or reactive power at the line terminals. An operating characteristic for the first case is shown in Figure 11, where fixed capacitance compensates for the no-load reactive power requirements of the generator, and six additional banks are switched on as the turbine output increases.

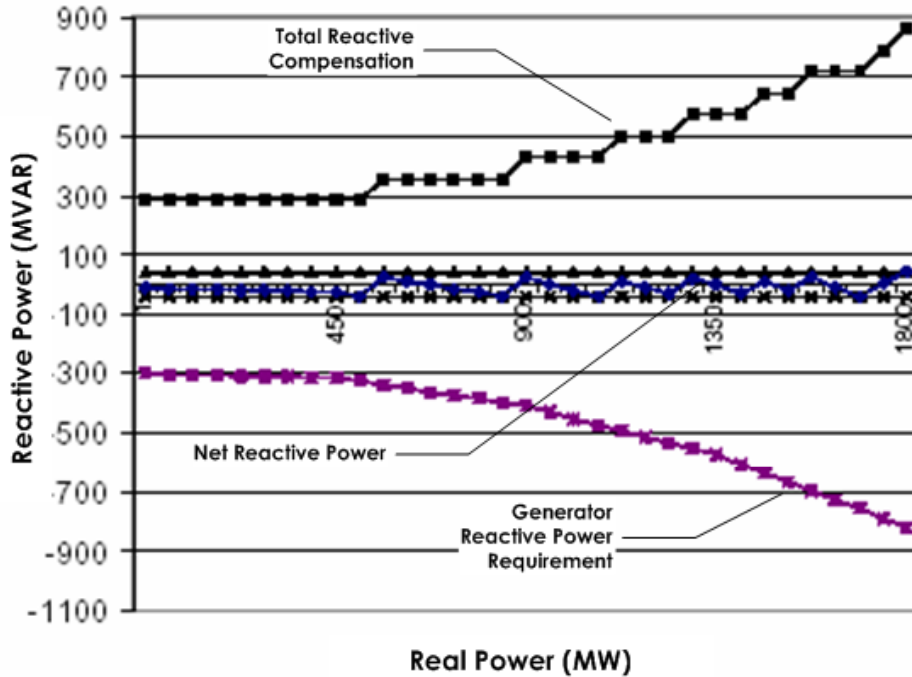

Figure 11:

Such systems will have switching delays to limit the number of capacitor switching events and to prevent cycling, so temporary operation outside the limits shown in the figure may be possible if generation is changing quickly.

Wind turbines with reactive power control capability may have a characteristic similar to that shown in Figure 12. In this example, reactive power within +/- 0.95 power factor is available over almost the entire operating range of the turbine, as indicated by the dashed lines. Note that the reactive power capability declines with generation level, down to zero when the turbine is not producing real power. The solid line is indicative of the reactive capability of a conventional synchronous generator, where the limitation arises due to stator current limits.

Reduction in reactive capability at low output levels might be an issue in some applications, especially if the turbine reactive power control is utilized to manage interconnection voltage. Since control would be available only when the wind plant is producing substantial amounts of real power, such schemes are sometimes discounted by transmission system operators, i.e. voltage control may be needed even when the wind plant is generating no power, so control that is not available at all times is of marginal value for the system.

If the wind plant is expected to provide voltage control benefits to the power system at all times, other design approaches could be used. Interconnect substation based equipment, such as switched capacitor banks or static var compensators, for example, would be available even under low or no wind conditions, thereby providing the power system operators with a service to be used for meeting needs of the system unrelated to the wind plant itself.

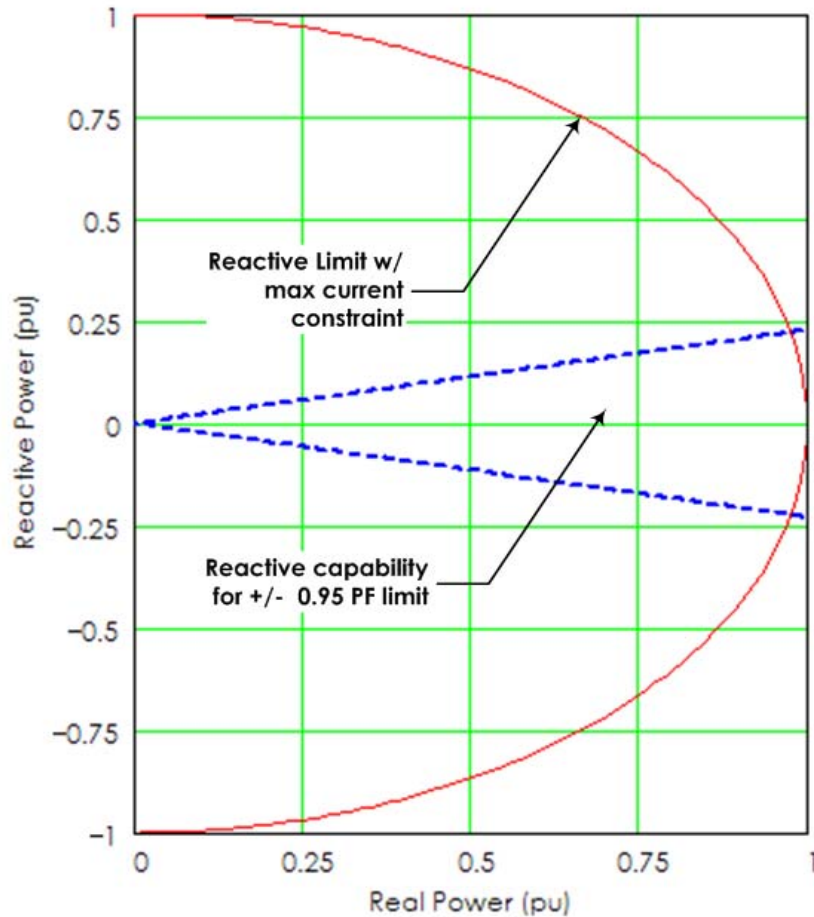

Figure 12: Illustration of wind turbine reactive power capability.

Wind plants vary in their ability to generate reactive power. Pure induction generators always consume reactive power. If for any reason the voltage becomes lower than expected or the generator exceeds its allowable slip, the consumption of reactive power is dramatically increased.

The most important influence of the wind plant infrastructure on the interconnection bus bar characteristics of the wind plant is on the net reactive power capability of the wind plant. Voltage profiles along the collector lines are an internal issue. For purposes of characterizing the plant for transmission studies, the static, dynamic, and load-dependent effects of the collector system on the net reactive power at the interconnection substation must be characterized. Figure 13 illustrates this influence with an example from an operating wind plant. Wind plant generation and net reactive power requirements are shown as functions of wind speed. In the figure, the net reactive power is entirely a function of reactive losses in the lengthy overhead collector lines, since the turbines are assumed to be operating at unity power factor. The stepped line shows how staged shunt capacitor banks on the collector lines might be deployed to account for this load-dependent reactive loss. Not shown on the diagram is how such a scheme would contribute to the dynamic nature of the plant. As wind speed – and power output – varies, so will the net reactive requirements. Details of the capacitor switching scheme are critical here, since there will be time delays and hysteresis associated with the capacitor bank controls. These parameters must be

selected with some knowledge of the time variation of wind generation on the collector line to prevent unnecessary capacitor switching operations while still effectively limiting voltage excursions and flicker.

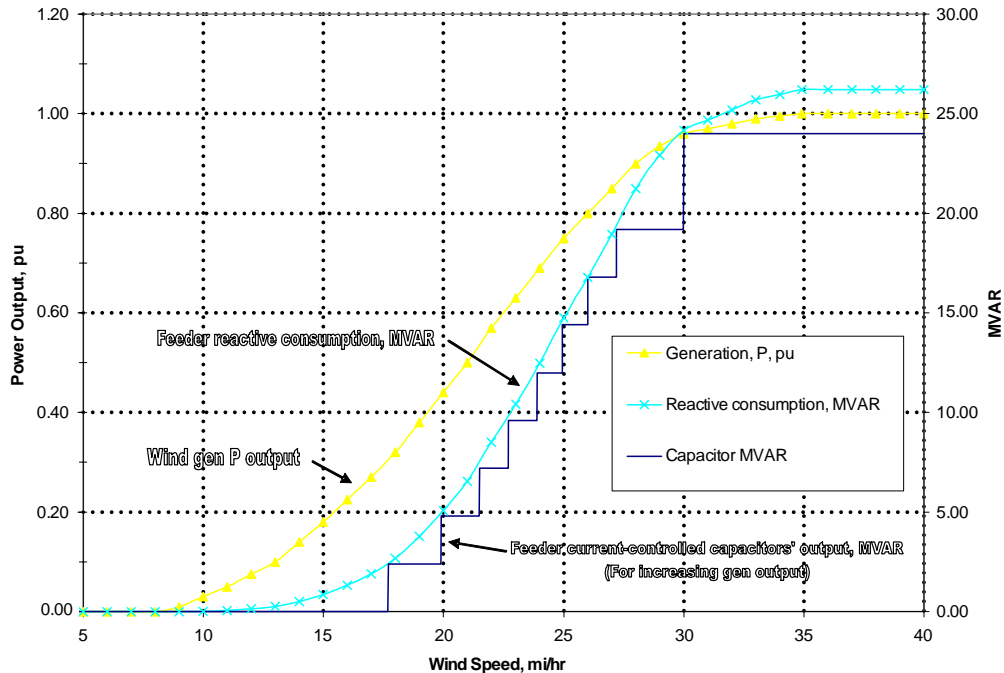

Figure 13:

It is normal practice to correct the power factor of the induction machine with capacitors, as shown above, and these may be switched in blocks normally controlled by the amount of active power being generated. The machines are considered more stable if they operate slightly in the inductive quadrant. This type of equipment offers little opportunity to be a transmission voltage correction device as the entire reactive power is generated from mechanically switched capacitors and its variability is tightly controlled to match the active power from the generator. A refinement is to replace some or all of the mechanically switched capacitance with thyristor switched capacitance, hence making the capacitance a smoothly adjusting and dynamically responding reactive power source. When the machine is off line, the capacitance may still be available.

DFIG machines can operate in either the capacitive or inductive quadrant. This is achieved by changing the angle of the rotor field relative to the stator field. This can be done in electronic switching time and therefore the device has the ability to dynamically generate and absorb reactive power. As energy is transmitted down the system, through transformers, the losses in each network component lead to a loss of electrical voltage.

### III. Wind Turbine and Wind Plant Response to Grid Frequency and Voltage Variations

Steady electrical frequency is an indicator of balance between supply and demand in an interconnected electric power system. If either total generation or load changes suddenly, system frequency will change correspondingly. Load in excess of generation will drive frequency lower; if generation exceeds load, frequency will increase.

Frequency must be tightly controlled in large interconnected power networks to maintain synchronism between hundreds or thousands of individual generating units. Under normal operating conditions, therefore, variations in system frequency are very small. Situations can and do occur, however, where the mismatch between load and generation can become significant, if only momentarily – the tripping of a very large generating unit or an entire power station, the loss of a major transmission line, etc. Under these conditions, system frequency might vary significantly until protective systems operate to take corrective action. While system frequency excursions are not uncommon, adherence to reliability standards and practices should result in the system “settling down” to a stable operating point with constant, regulated frequency.

A tenet of the underpinning principles for ensuring power system reliability is that the failure or misoperation of a single system element must not lead to cascading outages of other devices or equipment. For this reason, large wind plants must not respond to a frequency deviation resulting from, say, the loss of a large generating unit by tripping off-line. Such operation would likely increase the supply/demand mismatch and possibly lead to the loss of additional system elements.

#### Steady-State and Small-Signal Behavior

For power flow calculations, a wind plant can obviously be represented as a single generating unit at the interconnection substation. Determining the equivalent “reactive capability” of the plant, however, can be complicated since it will be a function of a large number of elements within the plant – turbine reactive compensation, reactive losses in collector lines, auxiliary compensation equipment such as collector line capacitor banks, etc. While fairly standard and well-known for conventional generating units, this characteristic has not been considered explicitly for many of the plants developed over the past decade.

Net reactive power is also a function of voltage if shunt capacitors are present as part of the plant reactive compensation scheme.

The dynamic nature of the wind resource can introduce a new dimension to power system studies, especially where the transmission interconnection is weak. Reactive power support for maintaining target voltages at the transmission interconnection will vary with the real power injected. Temporal variation of wind plant aggregate power is a very complicated function of a number of plant parameters and variables, but it also can be a defining factor for the dynamic characteristics of the reactive compensation system.

Additionally, the reactive compensation devices within the plant – turbines (with shunt capacitors or advanced controls), collector line capacitor banks, and possibly interconnect substation-based equipment – are dynamic devices themselves, with set points and delay for toggling on or off of switched devices and continuous control for static var capabilities.

Some of the factors that influence the variability of the aggregate production of a wind plant include

- Variations in wind speed at each turbine location in the plant;
- Topographical features that introduce turbulence and shear into the moving air stream across the geographical expanse of the wind plant;

- The mechanical inertia of individual turbines, which influences how the wind speed variations, turbulence, and wind shear affect the output of individual turbines
- The wind turbine control scheme, including the generator control and pitch regulation systems that determine how the electric power at the terminals of the turbine is influenced by fluctuating prime mover input;
- The number of turbines within the plant, since a larger number of turbines implies a larger geographical area for plant, and more statistical diversity in the local characteristics that contribute to output fluctuations;
- The grouping of turbines within the plant – if turbines are grouped into “strings”, rather than more uniformly distributed over the area of the plant, local fluctuations in wind speed will affect more than a single turbine at an instant of time.

Wind generation is often characterized as “intermittent”, but, to better understand how it can impact power system operations, it is useful to consider the output variability in more detail. In general, the wind generation is more easily understood as having variable output.

On the shortest time scales, say tens of seconds to minutes, the output of a wind plant can fluctuate because of varying wind speeds at the individual turbines comprising the plant due to effects of terrain and turbulence in the moving air stream. This is more likely the case in light to moderate winds, as modern wind turbines are capable of holding the output power “flat” for wind speed at or above the rated value. Measurement data shows that the fluctuations on this time scale as a fraction of the plant rating decrease in magnitude as the number of turbines in the plant increases.

Over longer time periods – tens of minutes to hours – wind plant generation also exhibits fluctuation, and may also trend down or up as the larger scale meteorology responsible for the wind changes. Passage of a weather front is an example. Experience is showing that these trends can be predicted, but the accuracy of the prediction degrades with time. Forecasts for the next hour, for instance will be much better than those for several hours ahead.

Longer-term forecasting for the next day is less accurate, especially when timing is important. Predictions of a weather front passing an area tomorrow can be relatively accurate, but the accuracy for predicting which hour it will pass will be much lower.

“Intermittent” or variable output, as the terms are applied to wind generation, encompass both the fluctuating characteristics along with the degree of uncertainty about when the resource will actually produce. Both of these attributes are important for power system engineers and operators who have come to understand well the fluctuations and uncertainties inherent in conventional generating resources and system loads. Because wind generation is new, these characteristics are only beginning to be quantified, and procedures for rigorously considering them in system studies have yet to be developed.

As of this writing, there are no practical analytical methods for characterizing the output fluctuations from a large wind plant. Direct measurements from operating wind plants, however, are providing some important insights into the complicated interaction of the factors listed above. The National Renewable Energy Laboratory (NREL) launched a program in CY2000 to collect high-resolution electrical measurement data from operating wind plants across the U.S. The database being compiled by NREL consists of continuous one-second samples of voltage, current, real power, and reactive power from wind plants in the Pacific Northwest, the upper Great Plains, and West Texas.

Preliminary analysis of this data has revealed much about the behavior of bulk-scale wind plants consisting of large numbers of individual turbines spread out over a significant geographical area. As the number of individual turbines increases, the per-unit variations in the aggregate output decline substantially. This characteristic is a critical factor for grid studies, as it provides a basis for

bounding the changes in real and reactive power over time that can influence system voltage and related indices such as flicker, as well as the impact on the generation/load balance in the control area.

### **Dynamic Response**

The electrical and mechanical technologies which comprise commercial wind turbines differ dramatically from the familiar synchronous generator and auxiliary systems that are used to represent almost all conventional generating equipment. And, instead of a small number of very large generating units, bulk wind plants can be made up of a very large number of relatively small machines. Until quite recently, these attributes have presented a difficult challenge to power system engineers engaged in evaluating transmission system impacts of large wind generation facilities.

Evaluating the dynamic response of the electric power system during and immediately following major disturbances such as faults is a critical engineering function for ensuring system security and reliability. Now that wind plants make up a non-negligible fraction of the generation assets in some control areas, their contribution to the system dynamic performance must be considered.

When subjected to a sudden and substantial change in terminal voltage or frequency, both the mechanical and electrical elements of the turbine along with the associated control systems influence its behavior. Consider the doubly-fed induction generator with flux vector control of torque via the power converter on the rotor circuit. When a fault on the transmission network causes the voltage at its terminals to sag to some fraction of normal,

- The magnitude of the main flux in the machine begins to decay in response to the reduced terminal voltage, and the position of the flux vector may suddenly change if there is a phase shift associated with the fault voltage
- The rotor power converter control almost instantaneously adjusts the quadrature axis rotor currents to “line up” with the new rotor flux vector.
- Since the rotor flux is no longer at the pre-fault value, the stator power of the machine is reduced accordingly. In response, the power converter control may try to increase the torque-producing component of rotor current.
- Because the electrical power output of the machine is now lower than the pre-fault value, there is net accelerating torque on the mechanical system which will increase the rotational speed of the machine.
- The increased rotational speed will cause the turbine blades to begin pitching to reduce the mechanical torque input to the machine and reduce speed
- When the fault is cleared and the terminal voltage returns to near normal, the rotor power converter control will readjust the position of the rotor current vector to again line up with the rotor flux vector
- Electric power output will jump back to (or slightly above, if the rotor current had been increased by the controller during the fault) the pre-fault value. Since mechanical power had been reduced by the pitch system, net decelerating torque on the mechanical system will cause rotational speed to decrease.
- The sudden changes in electromagnetic torque applied by the generator to the rotating shaft (at fault inception and clearing) excite the main mechanical resonance between the turbine blades and the generator inertia, such that these masses are now oscillating out of phase around the average speed of the rotating system.

- The oscillations in generator speed may be fed through the control system to produce oscillations in electric power at the stator terminals of the machine.

The response is depicted graphically in Figure 14, and Figure 15 shows an expanded view around the initiation and clearing of the system fault. Note how the vector control algorithm maintains control of the rotor (and stator) currents except for a few milliseconds at the beginning and end of the fault.

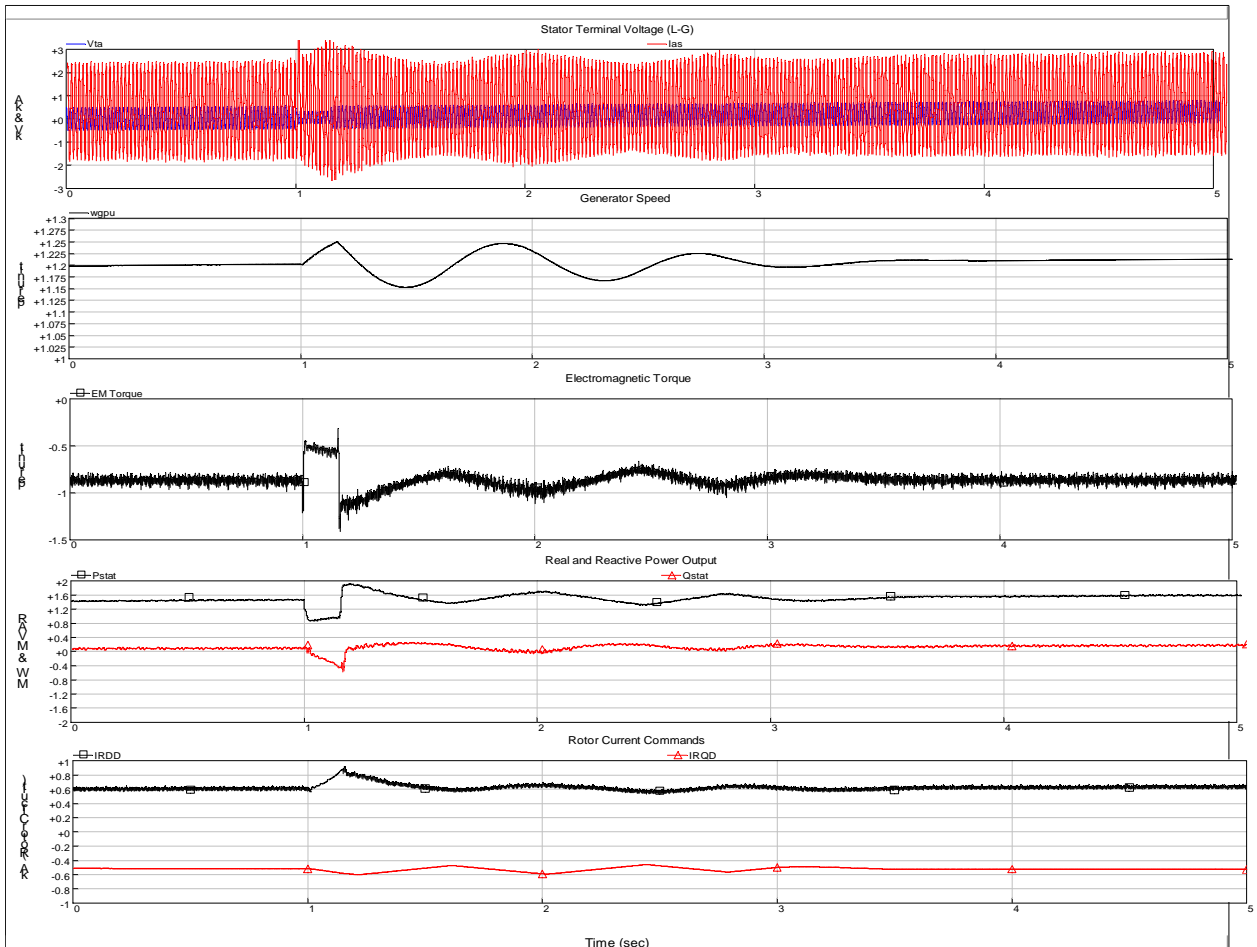

Figure 14: Wind turbine dynamic response to fault on the grid.

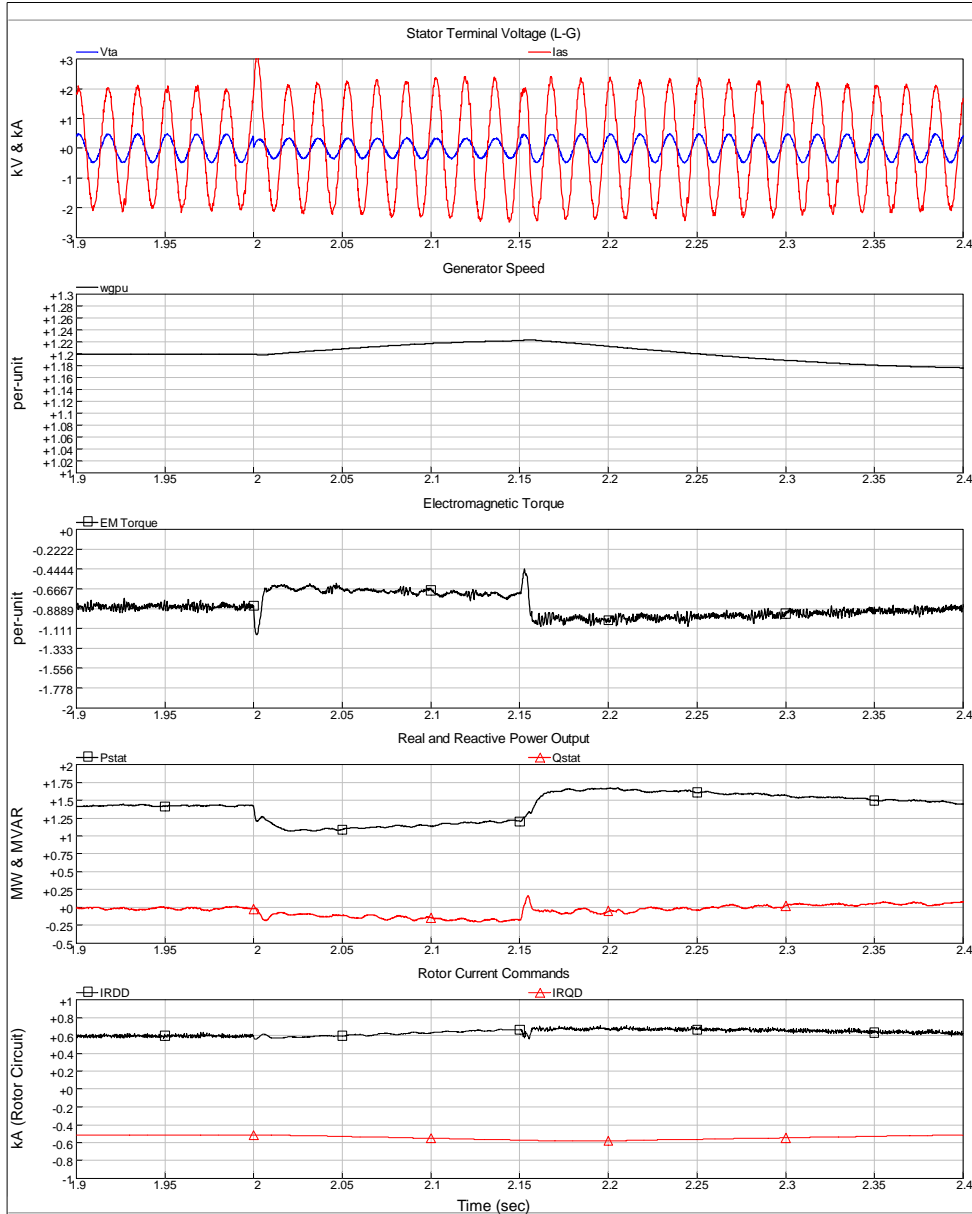

Figure 15: Expanded view of Figure 14.

While there are some similarities to the response of a synchronous generator to the same disturbance, the markedly different equipment and control comprising the wind turbine lead to a different dynamic response. While the sequence above is only an example for one type of wind turbine, it is indicative of the behavior that needs to be represented in dynamic simulations of the entire power system.

In addition, the response described is for a single turbine. What is important from the perspective of the power system is the aggregate response of all the turbines in the wind plant, along with the influence of any other dynamic elements such as static compensation or switched elements.

Research is only beginning into electro-dynamic equivalents for wind plants. There is agreement on a few general guidelines and principles for developing these dynamic equivalents. For remote disturbances – those originating on the transmission network, not within the wind plant itself – individual turbines can be considered coherent, i.e. they response as if they were a large single

machine of equivalent aggregate rating. This assumption is based on all turbines being of identical type and parameters, and that they “see” the disturbance at precisely the same instant and in roughly the same degree.

With some turbine technologies, there are nonlinearities in certain of the control blocks such that the response may be dependent on the pre-fault conditions at the turbine, namely the assumed generation level as a fraction of the rated value. If maximum generation conditions are being studied, then all turbines at the same pre-fault generation level is a good one. If for some reason partial generation conditions are of interest, aggregate dynamic performance of the plant could depend on how the total generation is allocated to individual turbines.

Because of the extensive medium voltage collector system that is part of many large wind plants, there is potentially an issue with differing pre-fault terminal voltages at turbines dependent on generation level and electrical location within the plant. And, as with the steady-state and small signal characterizations, the response of the plant in terms of reactive power may also be difficult to capture, unless the behavior at the interconnection bus bar is dominated by a single device such as a static var compensator located at the substation.

Fortunately, most of these detailed questions are likely of secondary importance, especially where the focus is on the power system as a whole and not some particular aspect of the wind plant response. Until new research findings indicate otherwise, relatively simple dynamic equivalents consisting of a single or small number of equivalent machines at the interconnection substations is the recommended approach.

#### ***Transient Response***

Dynamic simulations and studies of the interconnected power system are based on a number of assumptions to facilitate some simplifications in the representation of the dynamic components of the system. For some investigations, such simplifications are not valid or can obscure the aspects of the system model critical for the study.

Studies of sub-synchronous torsional interaction, control interactions, inadvertent islanding, etc. may require models with more detail than those used for system dynamic studies. Full transient models of all but the simple wind turbine technologies require information and engineering detail that can only be obtained from the wind turbine manufacturer. Studies of these types should be conducted collaboratively with technical personnel from the turbine designer.

#### ***Short Circuit Contributions***

Little guidance exists for calculating short-circuit contributions from large wind generation facilities. Analytical approaches are complicated for the following reasons:

- Commercial wind turbines employ induction machines for electromechanical energy conversion, which do not strictly conform to the standard procedures and assumptions used in calculation of short-circuit contributions on the transmission network.
- Generator control technologies employed in wind turbines– e.g. scalar or vector control of rotor current in a wound-rotor induction machine - can substantially modify the behavior of the induction machine in response to a sudden drop in terminal voltage, further complicating calculation of terminal currents during such conditions.
- Wind plants are composed of large numbers of relatively small generators, interconnected by an extensive medium-voltage network that itself influence fault contributions.

The short-circuit behavior of a squirrel-cage induction generator is fairly well known, and procedures are spelled out in the technical literature (such as the IEEE Brown Book) for considering these machines in short-circuit studies. These recommendations, however, apply most

directly to fault studies within large industrial facilities, and may require adaptation for transmission system fault studies.

In the remaining cases of the wound-rotor induction machines, the external components and accompanying control have very significant influence on the machine under network fault conditions, assuming that the control systems themselves are not bypassed or rendered inoperative as a consequence of reduced terminal voltage at the turbine.

The following paragraphs are intended as a qualitative description of the characteristics of the various wind turbine generator technologies under network fault conditions.

#### *Direct-Connect Squirrel Cage Induction Generator*

Induction generators are essentially induction motors that are driven at speed above their nameplate synchronous speed by some prime mover. Magnetic excitation necessary for torque production and power flow is drawn from the power supply system. The electric current necessary for magnetizing the iron core is responsible for much of the reactive power required by an induction machine.

When the source of excitation is removed from an induction machine, the main flux field collapses and torque production or power flow is no longer possible. It does take a finite amount of time for this field to collapse, however, during which time an induction machine will contribute current to a short-circuit on the power system. Also, if voltage is just reduced rather than removed completely as the result of a downstream fault, the main flux will decay to some new value, but provide necessary excitation for the machine to contribute to the fault. Contributions from induction motors are rarely considered in utility fault studies, but can be an important consideration for protective device coordination and rating within some industrial facilities. The IEEE Brown Book (Standard 399-1997) "IEEE Recommended Practice for Industrial and Commercial Power Systems Analysis" details procedures for calculating induction motor and generator contributions to short-circuits within facilities.

Figure 16 illustrates the behavior of a wind turbine employing a line-connected induction generator during a fault on the supply network. In the first cycle following fault inception, stator currents quickly build up to a value several times the rated current of the machine. The contribution during the first cycle can be estimated as the sum of: 1) a sinusoidal component approximately equal to the pre-fault terminal voltage divided by the sum of the subtransient reactance of the generator and the reactance of the equivalent network to the point of fault, and 2) a uni-directional (dc) component that depends on the reactance to resistance (X/R) ratio of the equivalent system impedance and the precise point on the terminal voltage wave where the fault is initiated. Both components decay in magnitude as the fault persists. The dc component decays at a rate governed by the X/R ratio. The decrease in the magnitude of the sinusoidal component is due to the decay in the main flux of the machine.

After a few cycles, the dc component has vanished, and the sinusoidal component has decreased in magnitude. It should be noted here that precise calculation of the short-circuit contribution requires a time-domain computer simulation with a relatively detailed differential equation representation of the induction machine. The aforementioned IEEE Brown Book acknowledges as much, and prescribes an approximate method for defining two equivalent reactances for the induction machine – one to be used for calculating the first cycle contribution, the other for a later time during the fault that would be associated with breaker clearing or interrupting requirements.

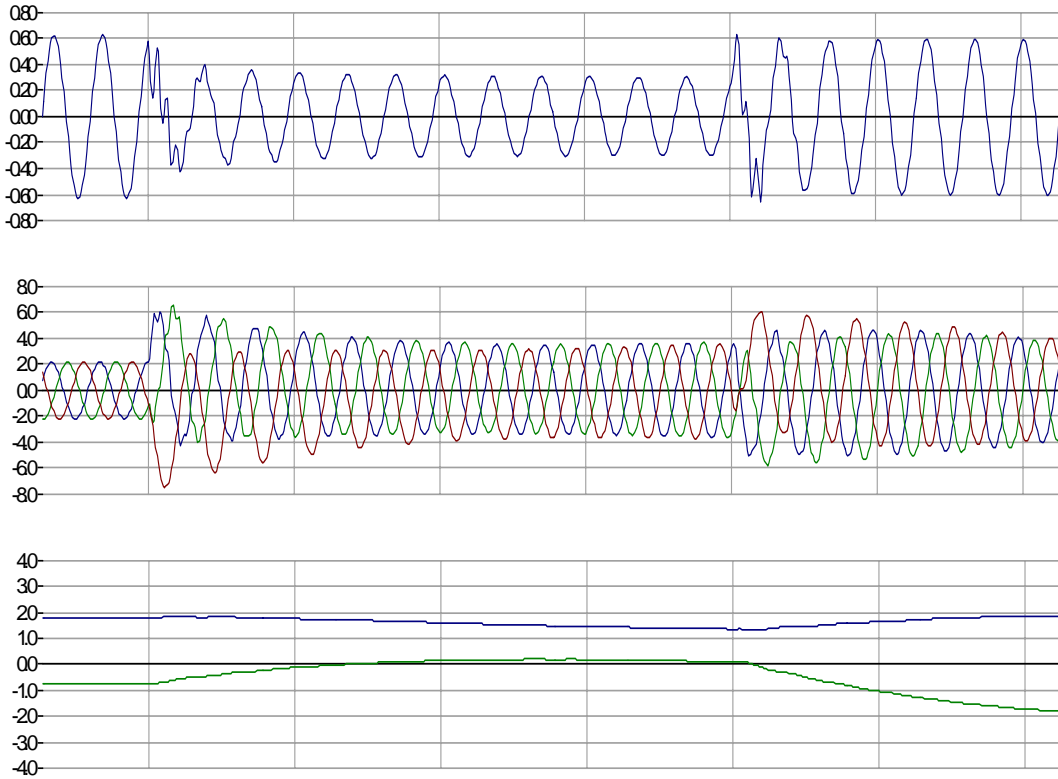

Figure 16: Contribution by a 2.0 MVA induction generator to a symmetrical three-phase fault. Shown are voltage at the machine terminals (top), stator currents (middle), and real and reactive power (generator convention) at the machine terminals (bottom).

***Doubly-Fed Induction Generator with Vector Control of Rotor Currents***

The 1.5 MW wind turbine from GE and its predecessor, the 750 kW turbines from Enron, are also based on a wound rotor induction generator. In these turbines, however, the rotor circuit is powered by a bi-directional static power converter (Figure 17). The fast response of the power converter coupled with sophisticated algorithms in the turbine and converter controller sections allows for precise and continuous adjustment of the instantaneous currents in the rotor circuits of the induction machine. Nearly instantaneous control of electromagnetic torque and turbine power factor is possible with this scheme.

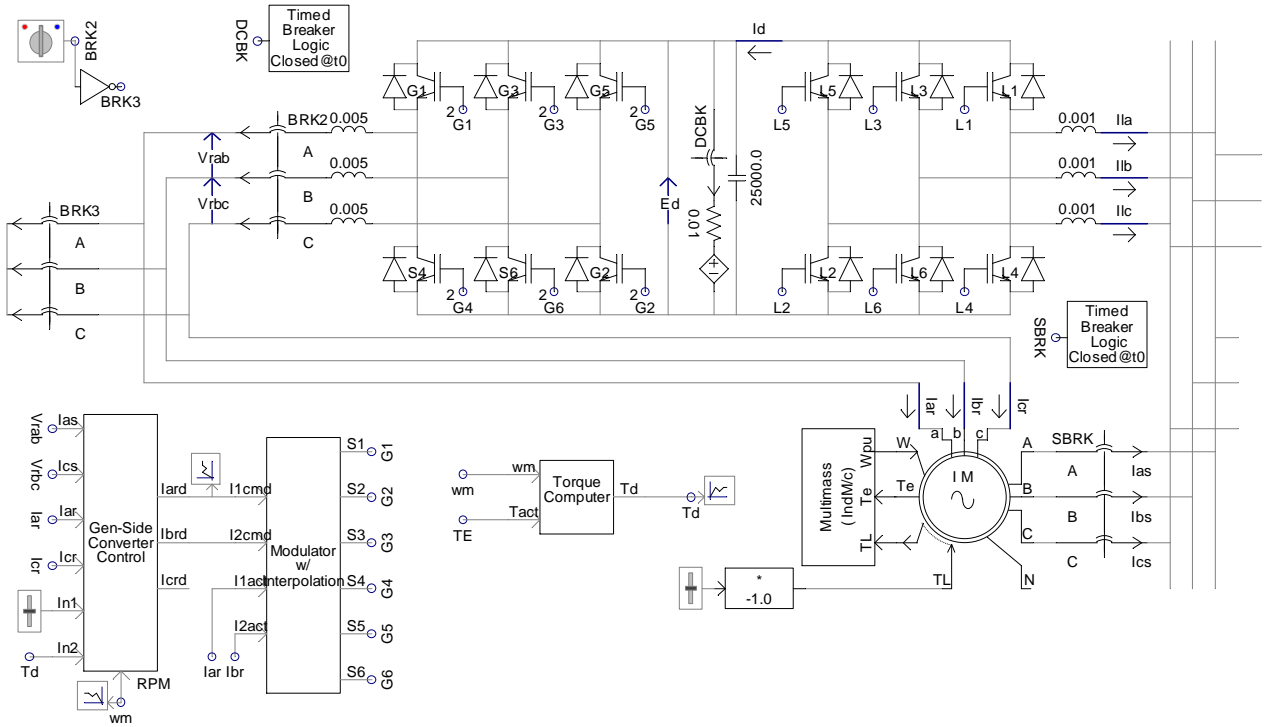

Figure 17: Transient model of a doubly-fed induction generator with vector control of rotor currents.

The fast action of the turbine and converter controls can limit the stator currents during a fault on the grid. Figure 18 details the turbine operation during a 150 ms grid fault. When the fault is initiated, the sudden change in terminal voltage magnitude and phase angle causes the power converter to momentarily “lose control” of the rotor currents, which is manifested as a one-quarter cycle “surge” in the stator current. Control is regained quickly, and the stator currents settle down to near their pre-fault value for the duration of the fault event (The slight rise in stator current magnitude during the fault is due to control actions attempting to restore the electromagnetic torque to the pre-fault value). When the fault is cleared, the phase and magnitude of terminal voltage again change suddenly, inducing another short-duration transient in the stator current. Again, however, control is regained, and stator currents return to the level desired by the turbine control.

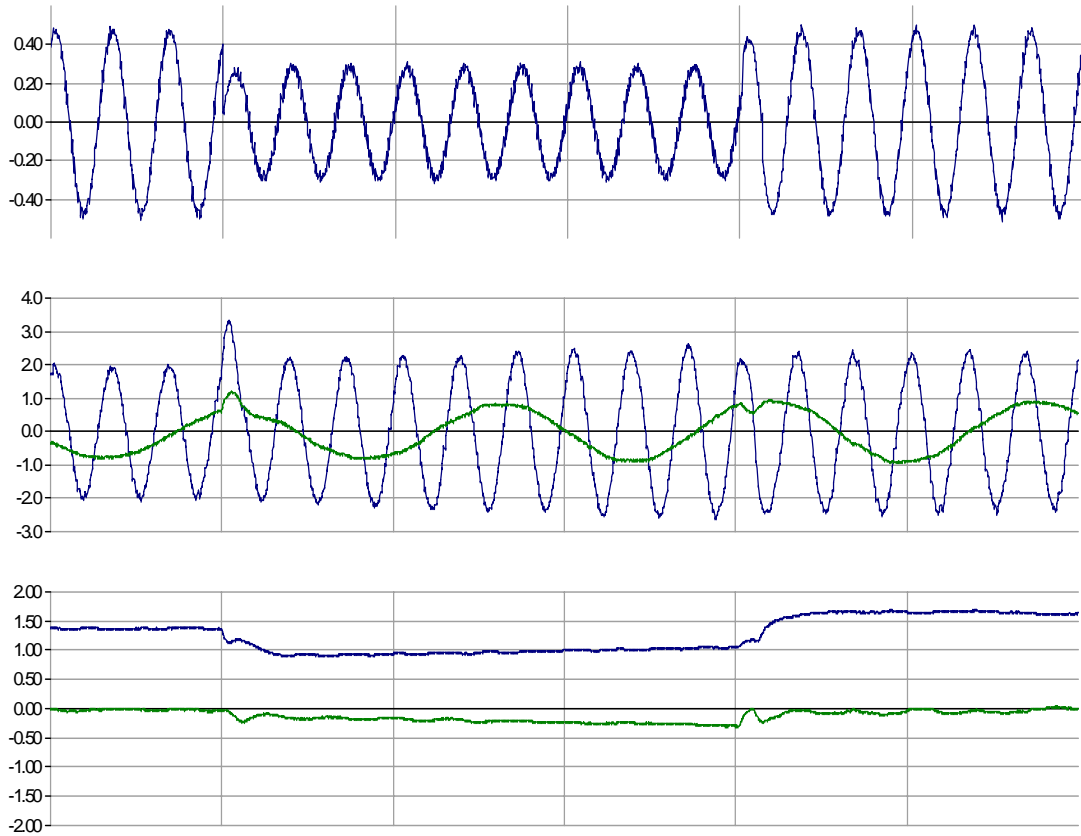

Figure 18: Short-circuit contribution from the GE 1.5 MW wind turbine for 150 ms grid fault. Shown are voltage at the machine terminals (top), stator currents (middle), and real and reactive power (generator convention) at the machine terminals (bottom).

It should be noted, however, that if the rotor power converter is bypassed, such as might be done to protect it from high rotor circuit voltage, the behavior of the turbine during the fault would be better characterized as a conventional induction machine. GE Power System Energy Consulting has developed an internal white paper specifying how the GE Wind Turbine would perform under conditions of rotor converter bypass.